

### Features:

- Support eCPRI wireless and 50GBASE-LR application
- Comply with IEEE 802.3cd 50GBASE-LR
- Comply with IEEE 802.3 50GAUI-1 C2M electrical interface.
- Management Interface comply with SFF-8472
- Comply with SFF-8432 with duplex LC connector
- Up to 10km transmission on SMF
- 2-wire interface with integrated Digital Diagnostic monitoring
- DFB laser and PIN receiver
- Support 10Gbps/25Gbps/26.5625GBd rate selection
- Single +3.3V power supply
- Power consumption lower than 2W
- Operating case temperature:  
Industry temp: -40~+85°C  
Commercial temp: 0~70°C



Notes: picture in this page is just for demo

### Regulatory Compliance

Table 1 – Regulatory Compliance

Feature	Standard	Performance
Electrostatic Discharge (ESD) to the Electrical Pins	MIL-STD-883E Method 3015.7	Class 1(>1000V for SFI pins, >2000V for other pins.)
Electrostatic Discharge (ESD) to the Duplex LC Receptacle	IEC 61000-4-2 GR-1089-CORE	Compatible with standards
Electromagnetic Interference (EMI)	FCC Part 15 Class B EN55022 Class B (CISPR 22B)	Compatible with standards
Immunity	IEC 61000-4-3	Compatible with standards
Laser Eye Safety	FDA 21CFR 1040.10 and 1040.11 EN60950, EN (IEC) 60825-1,2	Compatible with Class I laser product.
RoHS	EU 2015/863	Compliant with exemption 7C(I)

### Absolute Maximum Ratings

Table 2 – Absolute Maximum Ratings

Parameter	Symbol	Min.	Typical	Max.	Unit	Notes
Storage Temperature	TS	-40	-	+85	°C	
Operating Relative Humidity	RH	10	-	+85	%	

### Recommended Operating Conditions

Table 3 – Recommended Operating Conditions

Parameter	Symbol	Min.	Typical	Max.	Unit	Notes
Operating Case Temperature	T <sub>OPR</sub>	-40	-	85	°C	I-temp
		0		70	°C	C-temp
Power Supply Voltage	V <sub>CC</sub>	3.135	3.3	3.465	V	
Power Dissipation	P	-	-	2	W	
Data Rate	DR		26.5625	-	GBd	
Transmission Distance	TD	-	-	10	km	1

Note:

1. Measured with SMF.

### Optical and Electrical Characteristics

Table 4 – Transmitter Optical Specifications

Parameter	Symbol	Min.	Typical	Max.	Unit	Notes
Center Wavelength Range	$\lambda_c$	1304.5		1317.5	nm	1
		1300		1320		2
Modulation Format		PAM4				
Average Output Power	P <sub>OUT</sub>	-4.5	-	4.2	dBm	
Outer Optical Modulation Amplitude	OMA	-1.5	-	4	dBm	
TDECQ	TDECQ			3.2	dB	
Average Output Power (Laser Off)	P <sub>OUT-OFF</sub>	-	-	-30	dBm	
Extinction Ratio	ER	3.5	-	-	dB	
RIN <sub>15.6OMA</sub>	-	-	-	-132	dB/H z	
Optical return loss tolerance	-	-	-	15.6	dB	
Transmitter reflectance	-	-	-	-26	dB	

Notes:

1. For C temp 0~70°C

2. For I temp -40~85°C

**Table 5 – Receiver Optical Specifications**

Parameter	Symbol	Min.	Typical	Max.	Unit	Notes
Center Wavelength Range	$\lambda_C$	1295	1311	1325	nm	
Damage threshold	-	-	-	5.2	dBm	1
Average receive power		-10.8		4.2	dBm	
Receiver Power (OMA <sub>outer</sub> )	-	-	-	4	dBm	2
Receiver sensitivity (OMA <sub>outer</sub> )		Max(-8.4, SECQ - 9.8)			dBm	
LOS Assert	LOSA	-30	-		dBm	
LOS De-assert	LOS <sub>D</sub>	-	-	-11	dBm	
LOS Hysteresis	LOS <sub>H</sub>	0.5	-	-	dB	

**Notes**

- The receiver shall be able to tolerate, without damage, continuous exposure to an optical signal having this average power level. The receiver does not have to operate correctly at this input power
- Measured with a PRBS31Q test pattern @26.5625 GBd, BER≤2.4X10<sup>-4</sup>.

**Table 6 – Electrical Specifications**

Transmitter (Module Input)							
Parameter	Symbol	Min.	Typical	Max.	Unit	Notes	
Differential Data Input Amplitude	V <sub>IN,P-P</sub>	180	-	900	mVpp		
Input Differential Impedance	Z <sub>IN</sub>	90	100	110	Ω		
Tx_Fault	Normal Operation	V <sub>OL</sub>	-0.3	-	0.4	V	
	Transmitter Fault	V <sub>OH</sub>	2.4	-	V <sub>CC</sub>	V	
Tx_Disable	Normal Operation	V <sub>IL</sub>	-0.3	-	0.8	V	
	Laser Disable	V <sub>IH</sub>	2.0	-	V <sub>CC</sub> +0.3	V	
Receiver (Module Output)							
Differential Data Output Amplitude	V <sub>OUT,P-P</sub>	300	-	1000	mVpp		
Output Differential Impedance	Z <sub>O</sub>	90	100	110	Ω		
Rx_LOS	Normal Operation	V <sub>OL</sub>	-0.3	-	0.4	V	
	Lose Signal	V <sub>OH</sub>	2.4	-	V <sub>CC</sub>	V	

**Recommended Host Board Power Supply Circuit**

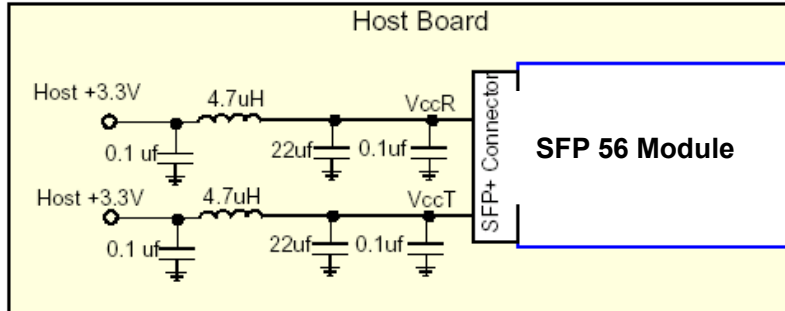

Figure 1, Recommended Host Board Power Supply Circuit

**Recommended Interface Circuit**

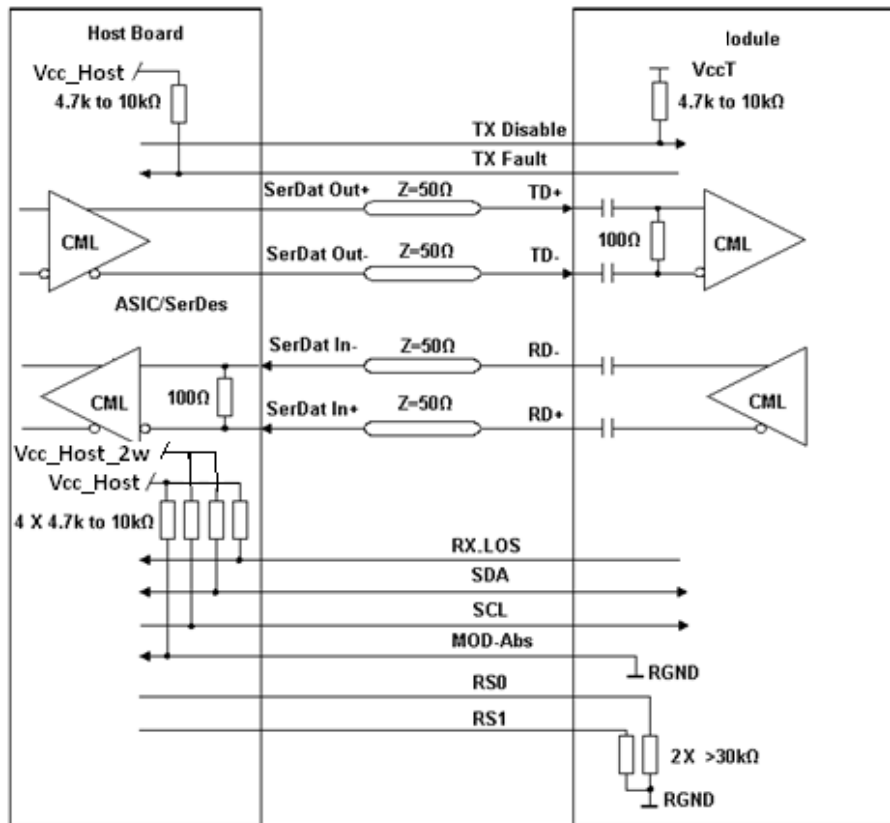

Figure 2, Recommended Interface Circuit

**Pin Definitions**

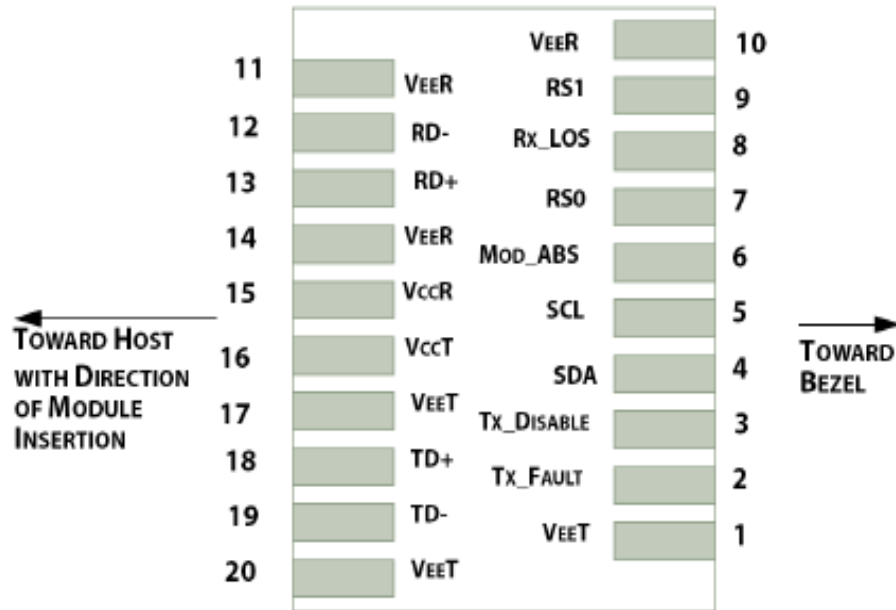

Figure 3, Pin View

**Table 7 – Pin Definitions**

Contacts	Logic	Symbol	Description	Notes
case		case	Module case	2
1		VEE T	Module Transmitter Ground	3
2	LVTTL-O	TX_FAULT	Module Transmitter Fault	4
3	LVTTL-I	TX_DISABLE	Transmitter Disable; Turns off transmitter laser output	5
4	LVTTL-I/O	SDA	2-wire Serial Interface Data Line(Same as MOD-DEF2 in INF-8074i)	6
5	LVTTL-I/O	SCL	2-wire Serial Interface Clock (Same as MOD-DEF1 in INF-8074i)	6
6		MOD_ABS	Module Absent, connected to VEE T or VEE R in the module	7
7	LVTTL-I	RS0	Rx Rate Select	
8	LVTTL-O	RX_LOS	Receiver Loss of Signal Indication(In FC designated as Rx_LOS and in Ethernet designated as Signal Detect)	4
9	LVTTL-I	RS1	Tx Rate Select	
10		VEE R	Module Receiver Ground	3

11		V <sub>EE</sub> R	Module Receiver Ground	3
12	CML-O	RD-	Receiver Inverted Data Output	
13	CML-O	RD+	Receiver Non-Inverted Data Output	
14		V <sub>EE</sub> R	Module Receiver Ground	3
15		V <sub>CC</sub> R	Module Receiver 3.3 V Supply	
16		V <sub>CC</sub> T	Module Transmitter 3.3 V Supply	
17		V <sub>EE</sub> T	Module Transmitter Ground	3
18	CML-I	TD+	Transmitter Non-Inverted Data Input	
19	CML-I	TD-	Transmitter Inverted Data Input	
20		V <sub>EE</sub> T	Module Transmitter Ground	3

Notes:

1. Labeling as inputs (I) and outputs (O) are from the perspective of the module.
2. The case makes electrical contact to the cage before any of the board edge contacts are made.
3. The module signal ground contacts, VeeR and VeeT, should be isolated from the module case.
4. This contact is an open collector/drain output contact and shall be pulled up on the host. Pull ups can be connected to one of several power supplies, however the host board design shall ensure that no module contact has voltage exceeding module VccT/R + 0.5 V.
5. Tx\_Disable is an input contact with a 4.7 kOhms to 10 kOhms pullup to VccT inside the module.
6. 2-wire interface.
7. The pins shall be pulled up with 4.7K-10Kohms to a voltage between 3.14V and 3.46V on host board.

### Rate select logic

Table 8 – Rate selection

A2.73.bit 4 is default to 0b, which allows both RS0(1) pins and RS0(1) bits control.

50G PMA4 Enable (A2.119.Bit2)	RS0 (pin #7)	Soft RS0 select (A2.110.bit3)	RS1 (pin #9)	Soft RS1 select (A2.118.bit3)	Rate (both Tx&Rx)
0	0	0	x	x	work on 10Gbps
0	0	1	x	x	work on 25Gbps
0	1	0	x	x	work on 25Gbps
0	1	1	x	x	work on 25Gbps
1	x	x	x	x	work on 50Gbps

**Mechanics Drawing**

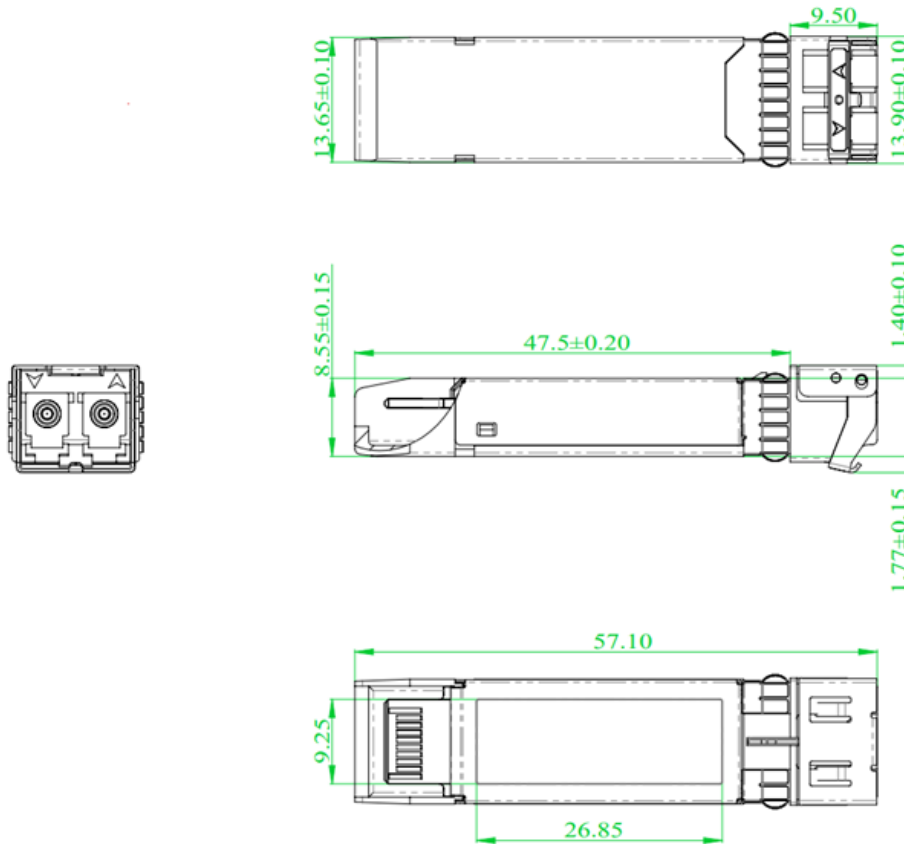

Figure 4 Mechanics drawing

**Order Information**

**Table 9 – Order Information**

Part No.	Application	Data Rate	Laser Source	Fiber Type
SP-50E-LR-CDFA	eCPRI/50GBASE-LR 0~70°C	26.5625 GBd	DFB	SMF
SP-50E-LR-IDFA	eCPRI/50GBASE-LR -40~85°C			

## Warnings

Handling Precautions: This device is susceptible to damage as a result of electrostatic discharge (ESD). A static free environment is highly recommended. Follow guidelines according to proper ESD procedures.

Laser Safety: Radiation emitted by laser devices can be dangerous to human eyes. Avoid eye exposure to direct or indirect radiation.

## Legal Notice

### IMPORTANT NOTICE!

All information contained in this document is subject to change without notice, at Source Photonics' sole and absolute discretion. Source Photonics warrants performance of its products to current specifications only in accordance with the company's standard one-year warranty; however, specifications designated as "preliminary" are given to describe components only, and Source Photonics expressly disclaims any and all warranties for said products, including express, implied, and statutory warranties, warranties of merchantability, fitness for a particular purpose, and non-infringement of proprietary rights. Please refer to the company's Terms and Conditions of Sale for further warranty information.

Source Photonics assumes no liability for applications assistance, customer product design, software performance, or infringement of patents, services, or intellectual property described herein. No license, either express or implied, is granted under any patent right, copyright, or intellectual property right, and Source Photonics makes no representations or warranties that the product(s) described herein are free from patent, copyright, or intellectual property rights. Products described in this document are NOT intended for use in implantation or other life support applications where malfunction may result in injury or death to persons. Source Photonics customers using or selling products for use in such applications do so at their own risk and agree to fully defend and indemnify Source Photonics for any damages resulting from such use or sale.

© Copyright Source Photonics, Inc. 2007-2022

All Rights Reserved.

All information contained in this document is subject to change without notice. The products described in this document are NOT intended for use in implantation or other life support applications where malfunction may result in injury or death to persons.

The information contained in this document does not affect or change Source Photonics product specifications or warranties. Nothing in this document shall operate as an express or implied license or indemnity under the intellectual property rights of Source Photonics or third parties. All information contained in this document was obtained in specific environments, and is presented as an illustration. The results obtained in other operating environments may vary.

THE INFORMATION CONTAINED IN THIS DOCUMENT IS PROVIDED ON AN "AS IS" BASIS. In no event will Source Photonics be liable for damages arising directly from any use of the information contained in this document.

## Contacts

### US Headquarters

8521 Fallbrook Ave, Suite 200  
West Hills, CA 91306, USA  
Tel: +1(818) 773-9044  
Fax: +1(818) 576-9486

### China

Building #2&5, West Export Processing  
Zone No. 8 Kexin Road, Hi-Tech Zone  
Chengdu, 611731, China  
Tel: +86-28-8795-8788  
Fax: +86-28-8795-8789

### Taiwan

9F, No 81, Shui Lee Rd.  
Hsinchu, Taiwan R.O.C.  
Tel: +886-3-5169222  
Fax: +886-3-5169213

[www.sourcephotonics.com](http://www.sourcephotonics.com)